

Introduction

The GPL117B series is a series of low dropout three-terminal regulators with a dropout of 1.15V(typ.) at 1A output current.

The GPL117B series provides current limiting and thermal shutdown. Its circuit includes a trimmed bandgap reference to assure output voltage accuracy to be within 1.5%. Current limit is trimmed to ensure specified output current and controlled short-circuit current. On-chip thermal shutdown provides protection against any combination of overload and ambient temperature that would create excessive junction temperature.

The GPL117B series has an adjustable version, that can provide the output voltage from 1.25V to 5V with only 2 external resistors.

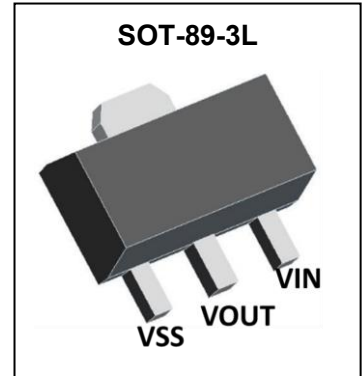

Features

- Low Dropout Voltage: 1.15V(typ.) at 1A Output Current
- Trimmed Current Limit
- On-Chip Thermal Shutdown
- Three-Terminal Adjustable or Fixed 1.25V, 1.8V, 2.5V, 3.3V, 5V

Applications

- PC Motherboard
- LCD Monitor
- Graphic Card
- DVD-Video Player
- NIC/Switch
- Telecom Modem
- ADSL Modem
- Printer and Other Peripheral Equipment

Order Information

GPL117B①②③④

Designator	Symbol	Description
①②③	Integer	Output Voltage e.g.1.8V=①:V, ②:1,③:8
④	KE	Package:SOT-89-3L

Marking:

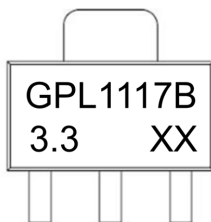

GPL117B : Product Code
3.3 :Voltage Code
XX : Data Code

Absolute Maximum Ratings ($T_A=25^{\circ}\text{C}$ unless otherwise noted)

Parameter	Symbol	Ratings	Units
Input Voltage	V_{IN}	20	V
Thermal Resistance from Junction to Ambient	$R_{\theta JA}$	250	$^{\circ}\text{C}/\text{W}$
Operating Junction Temperature Range	T_j	150	$^{\circ}\text{C}$
Storage Temperature	T_{stg}	-50~150	$^{\circ}\text{C}$
Lead Temperature(Soldering, 10 sec)	T_{solder}	260	$^{\circ}\text{C}$
ESD rating	Human Body Model -(HBM)	3	kV
	Machine Model- (MM)	250	V

Note: Stresses greater than those listed under "Absolute Maximum Ratings" may cause permanent damage to the device. These are stress ratings only, and functional of the device at these or any other conditions beyond those indicated under "Recommended Operating Conditions" is not implied. Exposure to "Absolute Maximum Ratings" for extended periods may affect device reliability.

Recommended Operating Conditions

Parameter	Min.	Nom.	Max.	Units
Supply voltage at V_{IN}			15	V
Operating junction temperature range, T_j	-25		125	$^{\circ}\text{C}$

Electrical Characteristics

GPL117B Series ($V_{IN} \leq 10V$, $T_A = 25^\circ C$, unless otherwise specified)

Parameter	Symbol	Conditions	Min.	Typ.	Max.	Units
Reference Voltage	V_{IROC}	$I_{OUT} = 10mA$, $V_{IN} = 3.23V(ADJ)$	1.231	1.250	1.269	V
		$10mA \leq I_{OUT} \leq 1A$, $2.75V \leq V_{IN} - V_{OUT} \leq 13.25V(ADJ)$	1.225	1.250	1.275	V
Output Voltage Range	V_{OUT}	$I_{OUT} = 10mA$, $V_{IN} = 3.8V(1.8)$	1.773	1.8	1.827	V
		$10mA \leq I_{OUT} \leq 1A$, $3.3V \leq V_{IN} \leq 12V(1.8V)$	1.764	1.8	1.836	
		$I_{OUT} = 10mA$, $V_{IN} = 4.5V(2.5V)$	2.463	2.5	2.538	
		$10mA \leq I_{OUT} \leq 1A$, $4V \leq V_{IN} \leq 12V(2.5V)$	2.450	2.5	2.550	
		$I_{OUT} = 10mA$, $V_{IN} = 5.3V(3.3V)$	3.251	3.3	3.350	
		$10mA \leq I_{OUT} \leq 1A$, $4.8V \leq V_{IN} \leq 12V(3.3V)$	3.234	3.3	3.366	
		$I_{OUT} = 10mA$, $V_{IN} = 7.0V(5.0V)$	4.925	5.0	5.075	
Line Regulation	LNR	$I_{OUT} = 10mA$, $1.5V \leq V_{IN} - V_{OUT} \leq 12V(ADJ)$			0.2	%
		$I_{OUT} = 10mA$, $1.5V \leq V_{IN} - V_{OUT} \leq 10.2V(1.8V)$			7	mV
		$I_{OUT} = 10mA$, $1.5V \leq V_{IN} - V_{OUT} \leq 9.5V(2.5V)$			7	
		$I_{OUT} = 10mA$, $1.5V \leq V_{IN} - V_{OUT} \leq 8.7V(3.3V)$			7	
		$I_{OUT} = 10mA$, $1.5V \leq V_{IN} - V_{OUT} \leq 7V(5.0V)$			10	
Load Regulation	LDR	$V_{IN} - V_{OUT} = 1.5V$, $10mA \leq I_{OUT} \leq 1A$			0.4	%
					7.2	mV
					10	
					13.2	
				20		
Adjust Pin Current				60	120	μA
Dropout Voltage	V_{dif}	$\Delta V_{REF} = 1\%$, $I_{OUT} = 1.0A$			1.3	V
Minimum Load Current	I_L	$1.5V \leq V_{IN} - V_{OUT} \leq 12V$ (ADJ only)		1.7	5	μA
Quiescent Current	I_q	$V_{IN} = V_{OUT} + 1.25V$ (ADJ except)			10	mA
Temperature Stability				0.5		%
Long-Term Stability		$T_A = 125^\circ C$, 1000hrs		0.3		%
RMS Output Noise (% of V_{OUT})		$T_A = 25^\circ C$, $10Hz \leq f \leq 10kHz$		0.003		%
Power Supply Rejection Ratio	PSRR	$f = 120Hz$, $C_{OUT} = 22\mu F$ Tantalum, $V_{IN} - V_{OUT} = 3V$, $I_{OUT} = 1A$		75		dB
Thermal Shutdown Hysteresis	ΔT_{SD}			25		$^\circ C$

Functional Block Diagram

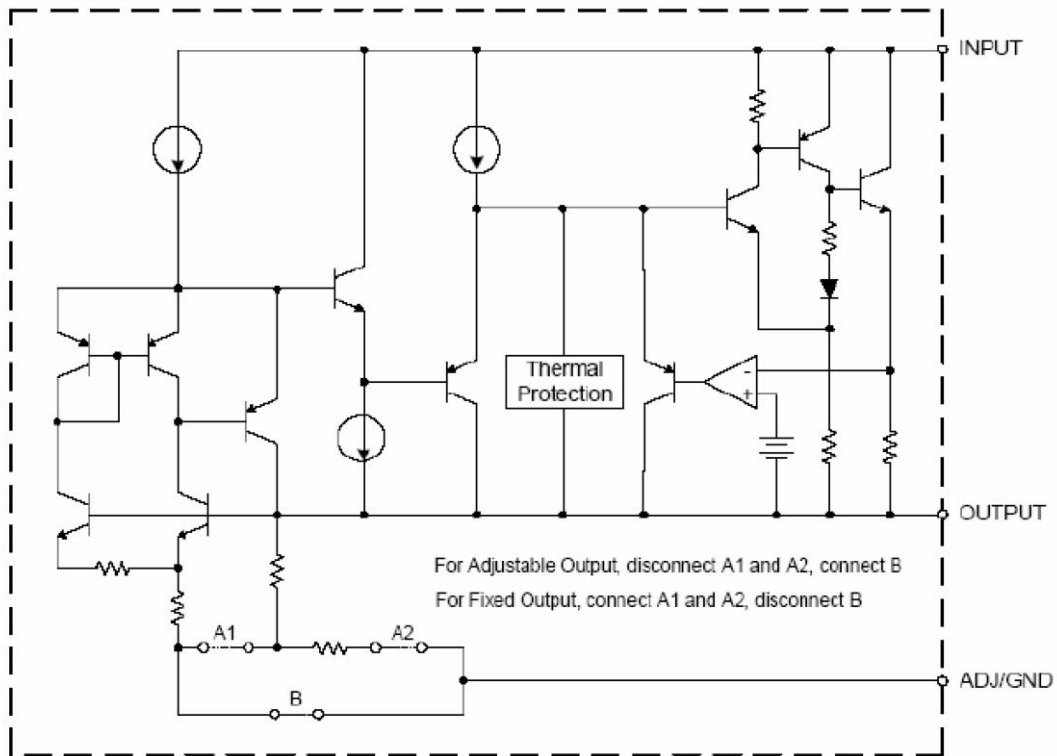

Typical Application Circuit

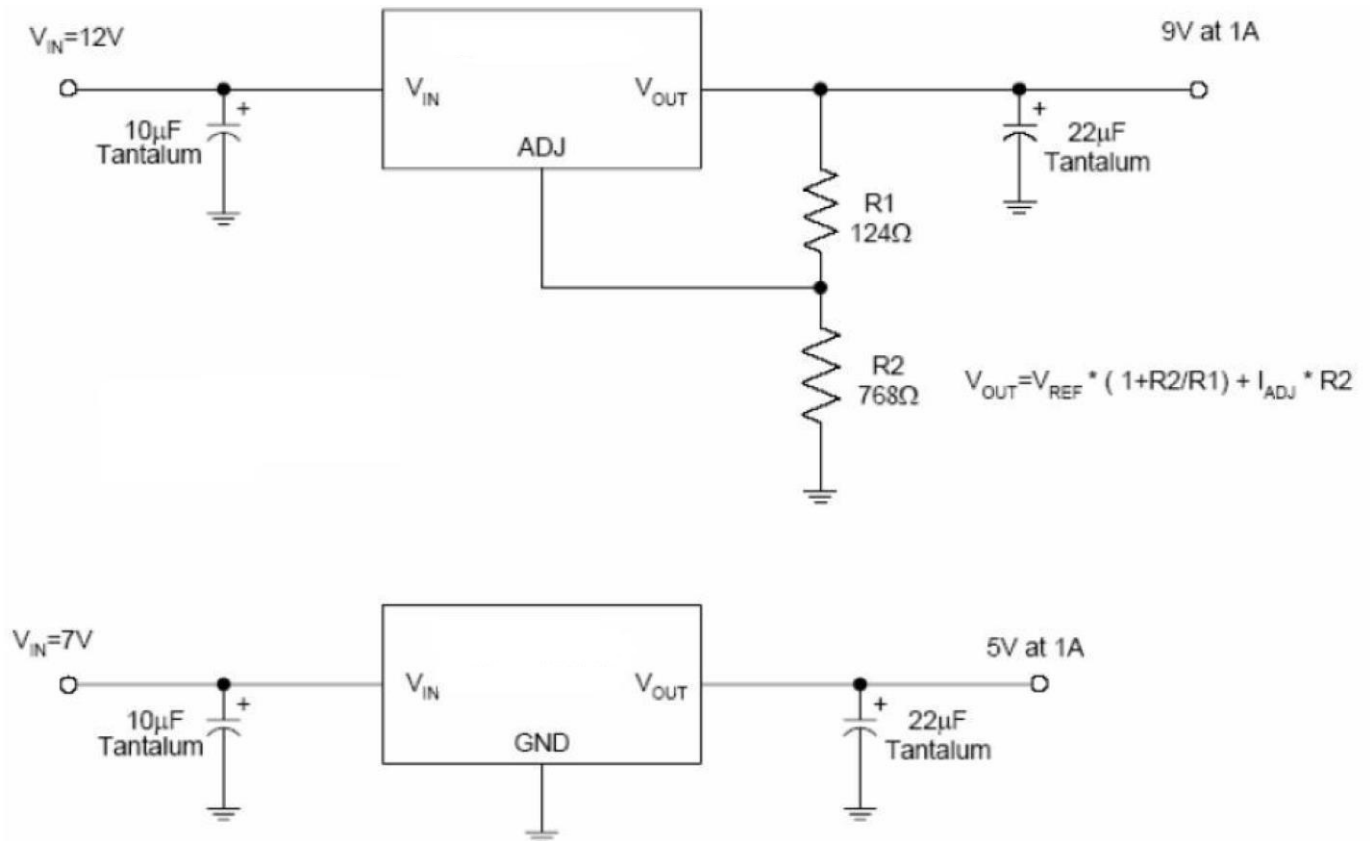

SOT-89-3L Package Outline Dimensions

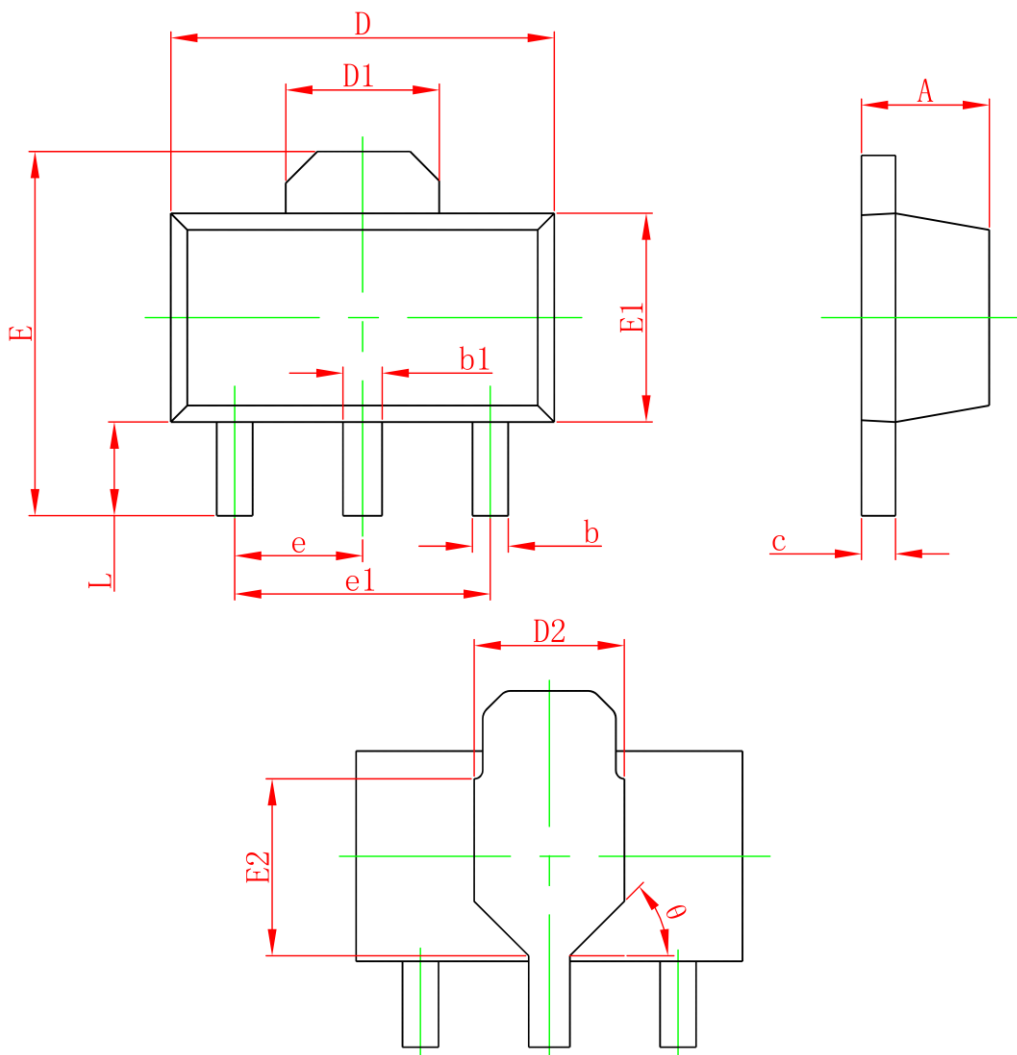

Symbol	Dimensions In Millimeters		Dimensions In Inches	
	Min.	Max.	Min.	Max.
A	1.400	1.600	0.055	0.063
b	0.320	0.520	0.013	0.020
b1	0.380	0.580	0.015	0.023
c	0.350	0.500	0.014	0.020
D	4.400	4.600	0.173	0.181
D1	1.650REF		0.065REF	
D2	1.650	1.850	0.065	0.073
E	3.900	4.400	0.154	0.173
E1	2.300	2.600	0.091	0.102
E2	1.900REF		0.075REF	
e	1.500TYP		0.059TYP	
e1	3.000TYP		0.118TYP	
L	0.900	1.200	0.035	0.047
θ	45°		45°	